

I CERTIFY THAT THESE DOCUMENTS WERE PREPARED OR APPROVED BY ME, AND I AM A FULLY LICENSED ARCHITECT UNDER THE LAWS OF THE STATE OF PENNSYLVANIA. LICENSE NO. PA000884. EXPIRATION DATE 05-30-2023.

CONTRACT DATE: 9/14/2021
 BUILDING TYPE: ENDEAVOR 50
 PLAN VERSION: APRIL 2020
 BRAND DESIGNER: A. NUNEZ
 SITE NUMBER: 315554
 STORE NUMBER: 040376

TACO BELL
 177 MILLERS RUN RD.
 BRIDGEVILLE, PA 15071



EXTERIOR ELEVATIONS

A4.0

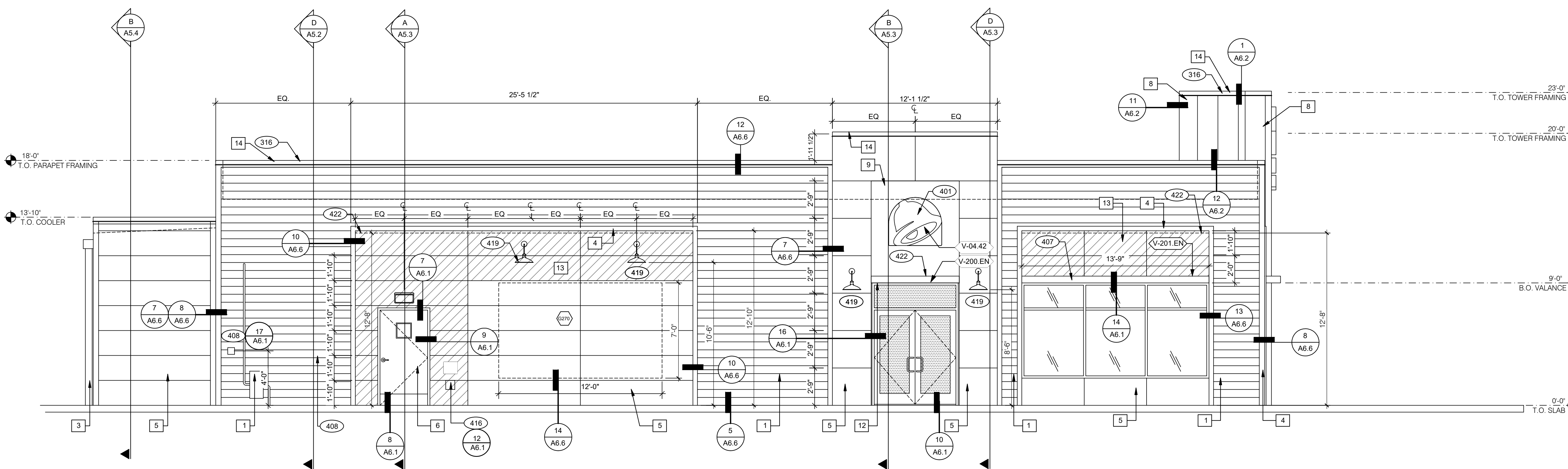

RIGHT SIDE ELEVATION 1/4"=1'-0" **1**

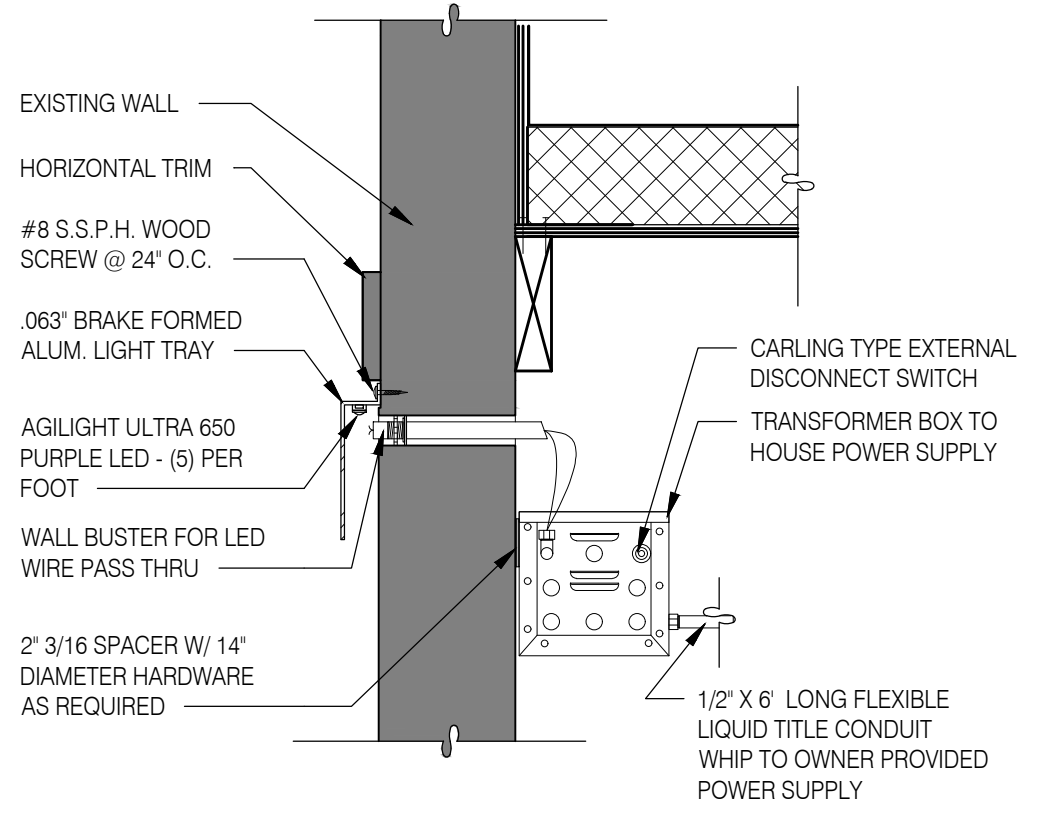

LED WALL WASHER DETAIL **I**

TYPE MARK	QTY	ITEM DESCRIPTION	LOC
TOWER			
V-04.3640	2	LARGE SWINGING BELL PURPLE LOGO 3' 6\"/>	

SIGNAGE **G**

MISCELLANEOUS
 A. SEE SHEET A1.1 'WINDOW TYPES' FOR WINDOW ELEVATIONS.
SEALERS (REFER TO SPECS)
 A. SEALANT AT ALL WALL AND ROOF PENETRATIONS.
 B. SEALANT AT ALL WINDOW AND DOOR FRAMES AND JAMB. DO NOT SEAL SILL @ WINDOWS.
 C. APPLY NEOPRENE GASKET (CONT.) BETWEEN BUILDING AND CANOPY.
CRITICAL DIMENSIONS
 A. REQUIRED CLEAR OPENING WIDTH TO ENSURE COORDINATION WITH STANDARD SIGNAGE/BUILDING ELEMENTS DIMENSIONS.
 NOTE: NO EXTERIOR SIGNS ARE WITHIN THE SCOPE OF WORK COVERED BY THE BUILDING PERMIT APPLICATION. THE GENERAL CONTRACTOR SHALL BE RESPONSIBLE FOR COORDINATING THE INSTALLATION OF ALL EXTERIOR SIGNS AND INSTALLATION OF REQUIRED BLOCKING AND ELECTRICAL CONNECTIONS FOR FINAL APPROVED SIGNS.

GENERAL NOTES **F**

PAINTING
 APPLICATOR MUST DO THEIR DUE DILIGENCE WITH PREPARATION.
 PRIMER: 1 COAT SW A24WB300
 FINISH: 2 COATS SW A82-100 SERIES. MATCH COLORS FROM MATERIAL SCHEDULE.
 A-100 EXTERIOR LATEX SATIN.

PAINT NOTES **E**

NOT USED	B
NOT USED	C

SYMBOL	ITEM/MATERIAL	MANUFACTURER	MATERIAL SPEC	COLOR	ALTERNATE MFR.	ALTERNATE COLOR	CONTACT INFORMATION
1	SIDING	JAMES HARDIE	ARTISAN V-GROOVE RUSTIC 144\"/>				

EXTERIOR FINISH SCHEDULE **H**

KEY NOTES **D**

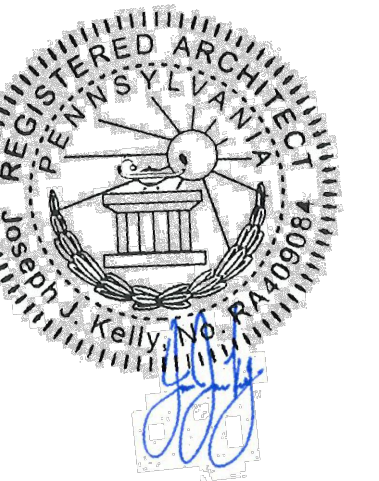

I CERTIFY THAT THESE DOCUMENTS WERE PREPARED OR APPROVED BY ME, AND I AM A FULLY LICENSED ARCHITECT UNDER THE LAWS OF THE STATE OF PENNSYLVANIA. LICENSE NO. RA000084. EXPIRATION DATE 09/30/2023.

CONTRACT DATE: 9/14/2021
 BUILDING TYPE: ENDEAVOR 50
 PLAN VERSION: APRIL 2020
 BRAND DESIGNER: A. NUNEZ
 SITE NUMBER: 315554
 STORE NUMBER: 040376

TACO BELL
 177 MILLERS RUN RD.
 BRIDGEVILLE, PA 15071



EXTERIOR ELEVATIONS

A4.1

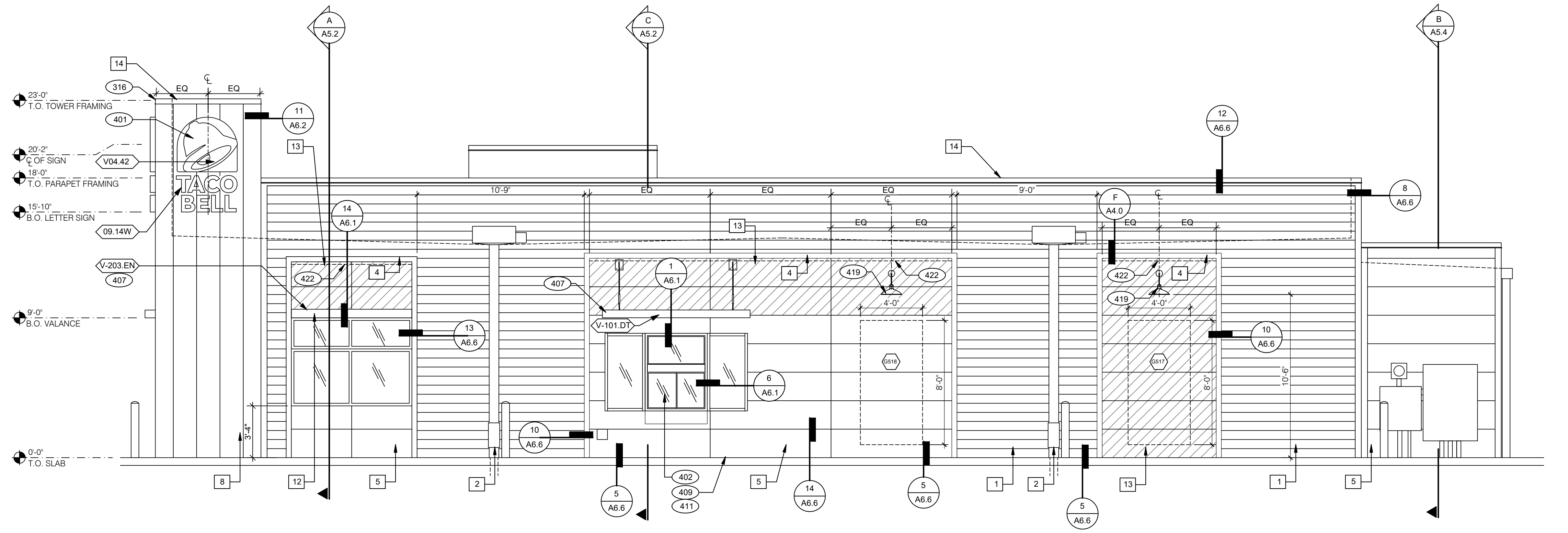

LEFT SIDE ELEVATION 1/4" = 1'-0" 1

- KEY NOTES**
- 316 METAL PARAPET CAP.
 - 401 BUILDING SIGN BY VENDOR. REQUIRES ELECTRICAL. SEE ELECTRICAL PLANS.
 - 402 DRIVE THRU WINDOW. SEE SHEET A1.0 AND A1.1.
 - 407 METAL CANOPIES BY SIGNAGE VENDOR. SEE SCHEDULE FOR FINISH.
 - 409 ASSUME D/T LANE SURFACE IS 6" BELOW THE FINISH FLOOR. REFER TO GRADING & SITE PLAN.
 - 411 CONCRETE CURB.
 - 419 EXTERIOR LIGHT FIXTURE. COORDINATE WITH ELECTRICAL DRAWINGS.
 - 422 PURPLE LIGHT WALL WASHER, PROVIDED BY SIGNAGE VENDOR. SEE DETAIL THIS SHEET.

KEY NOTES A

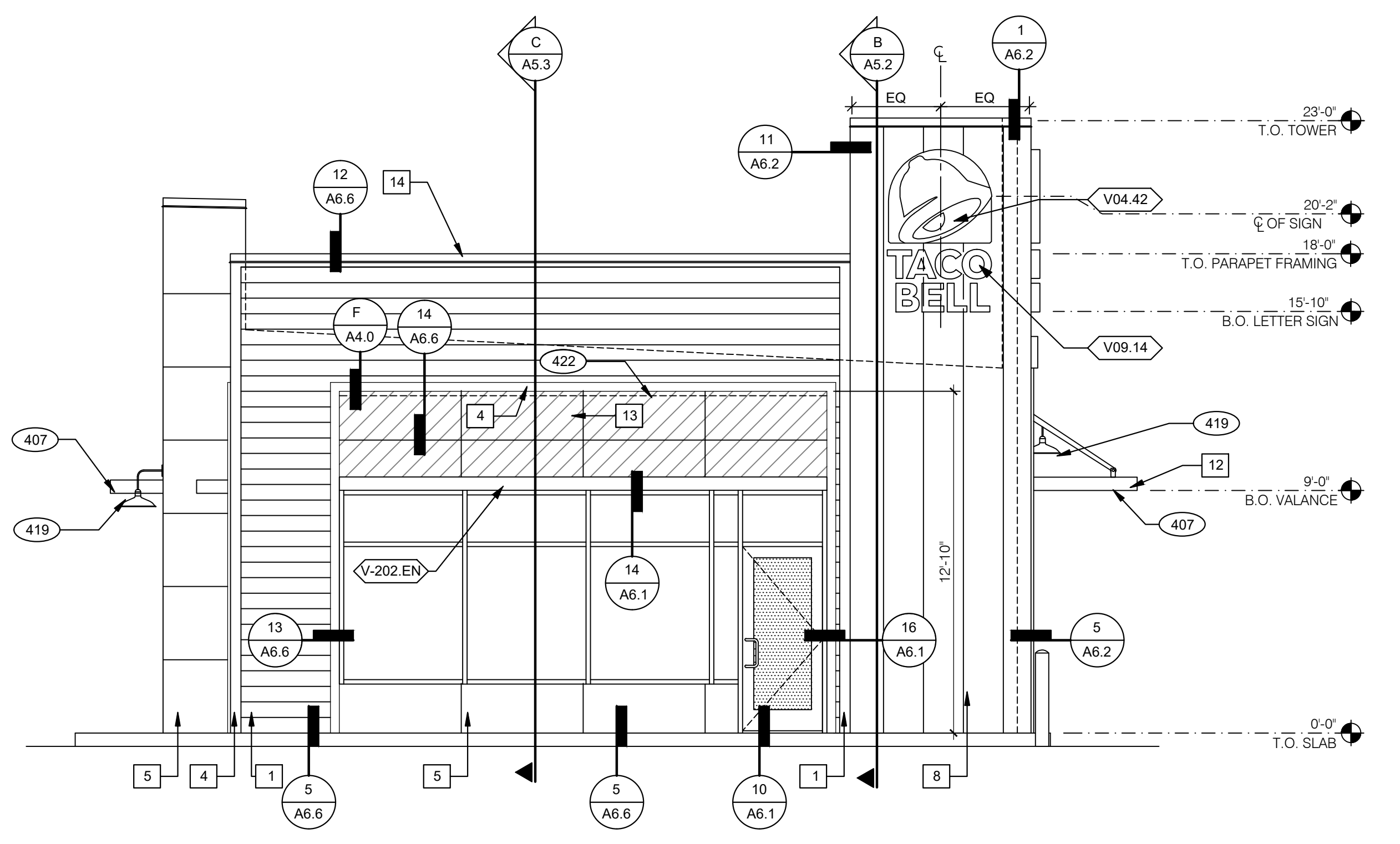

FRONT ELEVATION 1/4" = 1'-0" 2

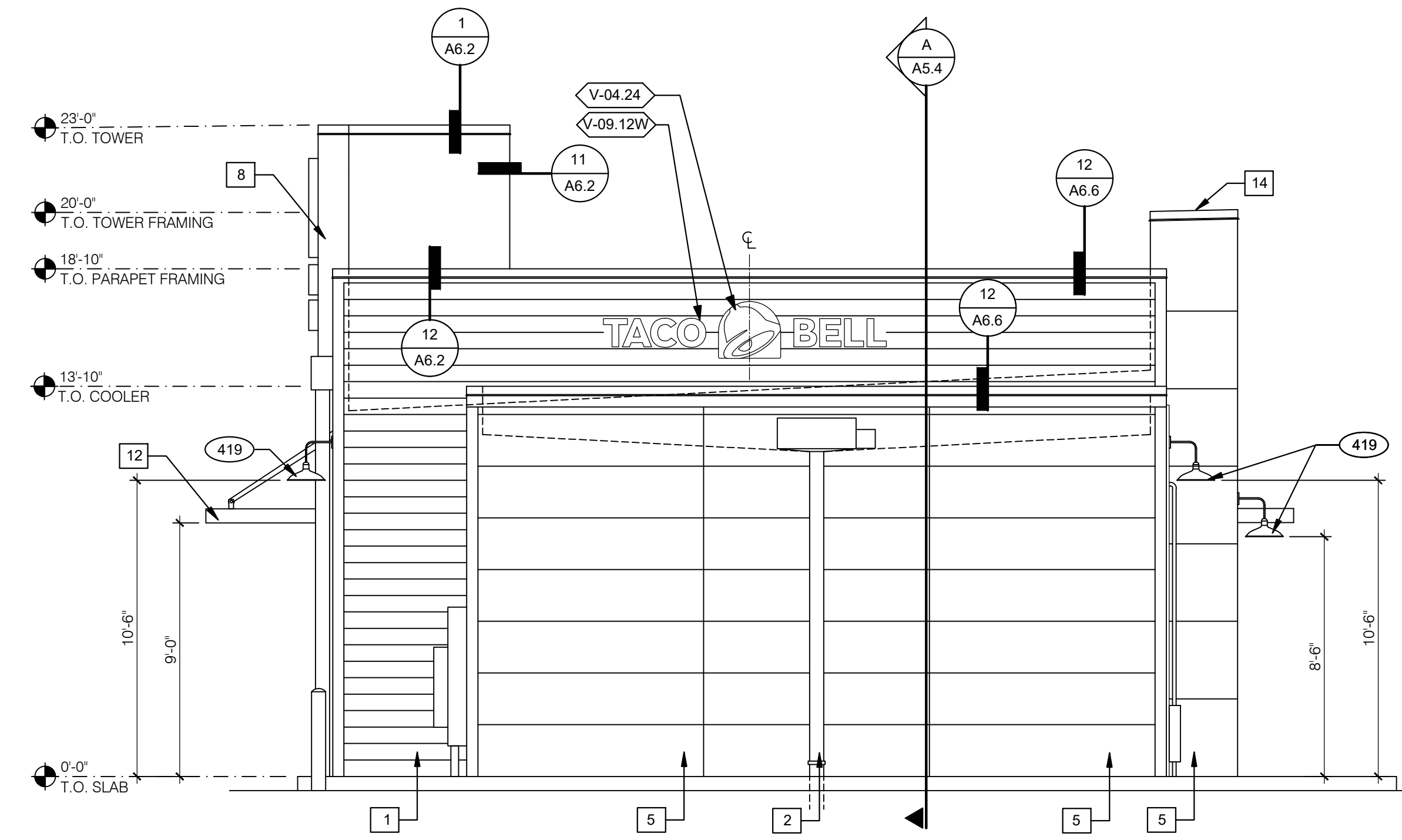

REAR ELEVATION 1/4" = 1'-0" 3